

Modular Jig & Fixture Platform System

Works with all **INCRA Track** & **INCRA T-Track** Components and Accessories

Build-It Components

- Large Build-It Panel
- Small Build-It Panel
- T-Slot Panel Connector
- 18" or 24" Miter Slider
- INCRA Build-It Clamp
- INCRA Build-It Bracket
- INCRA Build-It Knobs
- INCRA T-Track
- INCRA T-Track PLUS
- INCRA Track (not shown)
- INCRA Shop Stop (not shown)

Sliding Cutoff Table Showing Major Components & Features of the System

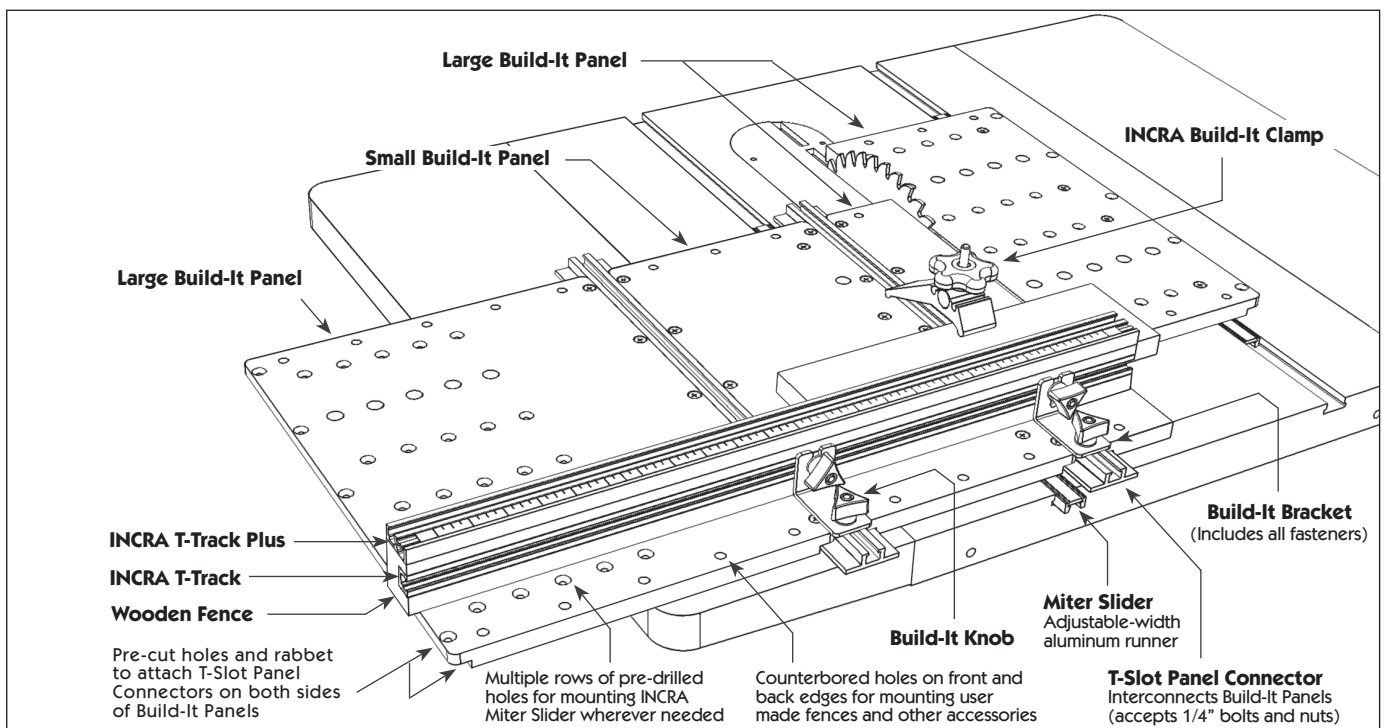

The INCRA "Build-It" Modular Jig & Fixture Platform System

The INCRA Build-It Modular Jig & Fixture Platform System is a highly versatile NEW method for quickly and easily creating an extremely wide variety of common and special purpose jigs, fixtures and those one-of-a-kind work helpers that you typically find hanging on the walls and rafters in just about any woodshop.

The Build-It System begins with INCRA's Miter Slider adjustable aluminum runners. With hundreds of thousands of units already in circulation, these tried and true jig and fixture runners have become a workshop staple for the production of sliding and fixed base jigs.

But it's the NEW INCRA Build-It Panels and T-Slot Panel Connectors that put the punch in this system. The Build-It Panels are pre-cut and pre-drilled to instantly accept all of the components of the system. You can add a Miter Slider in seconds and it's automatically square to your saw blade with no tedious measuring or drilling required, then mount a fence in moments using the counterbored mounting holes. The glue that holds everything together is INCRA's innovative NEW T-Slot Panel Connector. These specially designed aluminum components serve to simultaneously interconnect the panels and provide a rock solid T-Slot for adding and holding jig accessories, fences, stops and Build-It Clamps. With INCRA's NEW Build-It Modular Jig & Fixture Platform System you just connect the parts with a screwdriver and the included fasteners. **The possibilities are endless!**

The INCRA **Build-It** assembly shown in the instructions that follow was chosen to illustrate a configuration using all of the main components of the system and requiring each of the few simple assembly and trimming operations that are likely to be encountered when putting the components together. Just remember that the example shown is by no means the only configuration possible. By using different combinations of the Build-It Panels, T-Slot Panel Connectors and Miter Sliders, hundreds of highly useful configurations are possible - like those shown on the opposite side of this instruction card. And that's just the beginning!

Also, keep in mind that while the table saw chosen to illustrate these instructions is an important candidate for sliding jigs and fixtures, there are many other stations in the shop that will benefit from the increased safety, accuracy and repeatability afforded by shop-made jigs. The NEW INCRA Miter Slider owner's manual includes specific plans for some useful common and specialty jigs that take advantage of the unique features of the Built-It System's components. Don't forget to check out the variety of great books already available on the subject of beneficial jigs and fixtures for your workshop. Now let's get started...

Left or Right Miter Slot?

While many tools in your shop like the band saw, router table or sanding station have only one miter channel, the table saw has two, and often a choice must be made to determine on which side of the blade the "business" side of your jig will slide. In choosing, just remember that for any cut requiring a tilted saw blade, you'll want the blade to tilt safely away from the main components of your jig, and most importantly, away from your hands. All of the instructions to follow will illustrate only a left side of blade assembly.

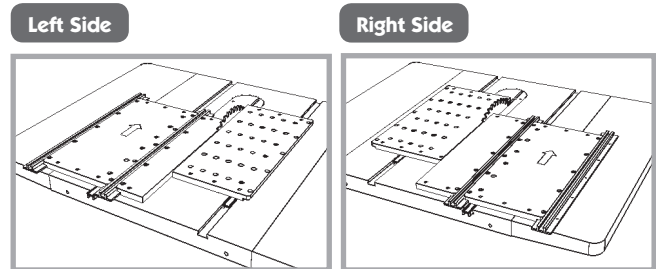

1. Adjust Miter Slider and Attach Build-It Panel

Begin by adjusting an INCRA Miter slider at each of the expansion mechanism locations for a good sliding fit in your table saw's miter slot. Now attach a small Build-It Panel to the Miter Slider as shown in **Fig. 1** using the (4) 10-24 x 3/4" flat head Phillips screws supplied with the Miter Slider.

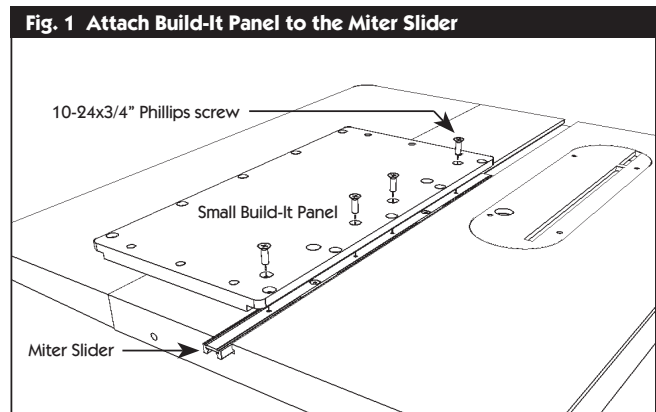

2. Attach Panel Connectors

Using the supplied 10-24 x 1/2" flat head Phillips screws, attach a panel connector to each side of the small Build-It panel, **Fig. 2**. **CAUTION: Make sure that no part of the aluminum Panel Connector overlaps the projected line of cut!**

This simple assembly can be used for a variety of jigs. The T-slots on the twin Panel Connectors provide an easy and secure means of attaching the components of your jig's design to the sliding Build-It platform using standard 1/4-20 hex bolts. Just take a look at the tenoning & raised panel cutting fixture in **Fig. 3**, then let's keep building.

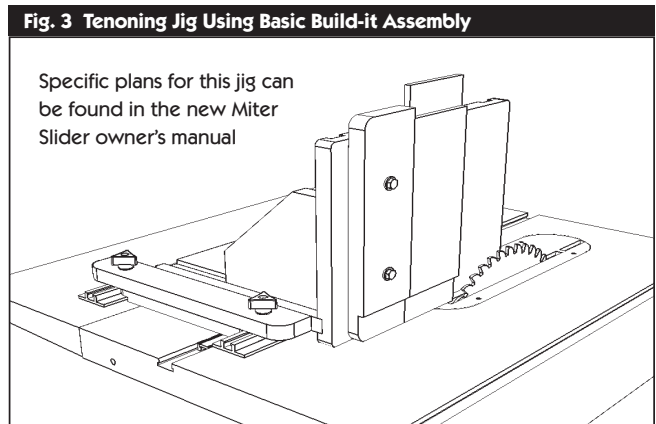
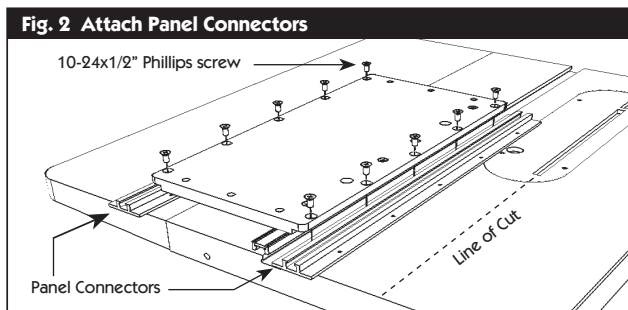

3. Extend Build-It Panel to Blade

While the T-Slot Panel Connectors are a useful and important commodity in attaching user made jig components, fences, stops and Build-It Clamps, they also provide an easy means of adding additional Build-It Panels to expand the size of your jig design. For example, you might want to extend support for your jig design to the blade. A large Build-It Panel is often a good choice here. Just attach the panel as shown in **Fig. 4** with the supplied 10-24x1/2" flat head Phillips screws. You'll want the area on the panel with the largest concentration of mounting holes positioned away from the small panel. Now we'll trim the panel to your saw blade.

Fig. 4 Extend Build-It Panel to Blade

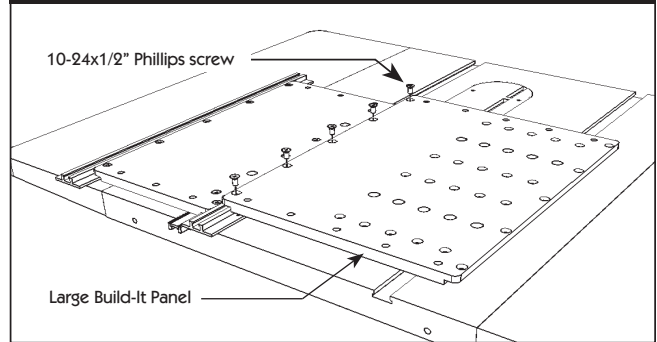

4. Trim Build-It Panel to Blade

BLADE ANGLE NOTE: If the primary use for your jig's design will be to make 90 deg. vertical cuts, be sure that the blade is set to 90 deg. before continuing. Raise your blade about 3/4" and make a cut by sliding the Build-It assembly to remove the portion of the large Build-It Panel that extends across the line of cut, **Fig 5**. Reserve the cutoff for later use as described in Step 6.

With a Build-It Panel extending all the way to the blade, your Build-It assembly can now be used to support a workpiece for crosscut operations like the simple "shooter board" jig shown in **Fig. 6**. Now let's add some size to our panel configuration for use with larger workpieces.

Fig. 5 Trim Build-It Panel to Blade

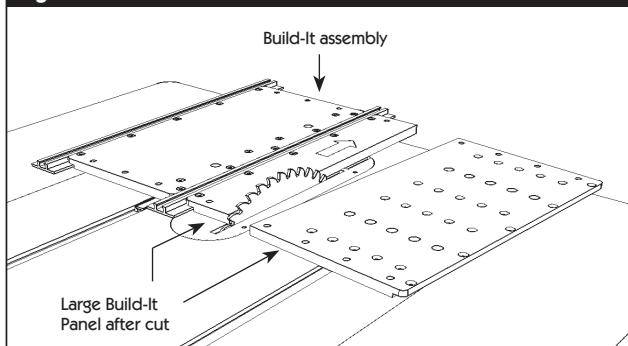
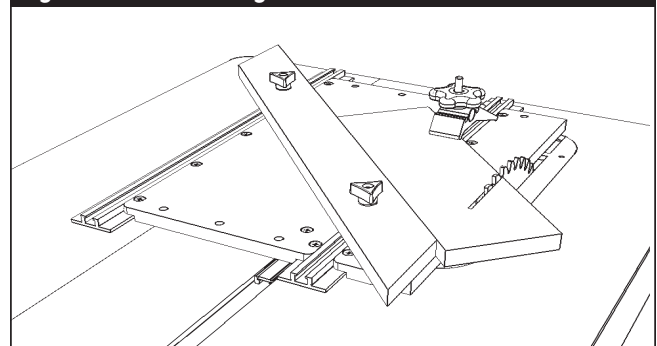

Fig. 6 "Shooter Board" Jig



5. Increase Build-It Assembly Size

You can now add additional Build-It Panels and T-Slot Panel Connectors as required to create a support platform to fit the size and scope of your project needs. In **Fig 7**, we've added a large Build-It Panel to the left edge of our assembly to increase workpiece support. Now, let's take a look at how you can use the cutoff reserved from Step 4 to extend workpiece support beyond the blade.

Fig. 7 Increase Build-It Assembly Size

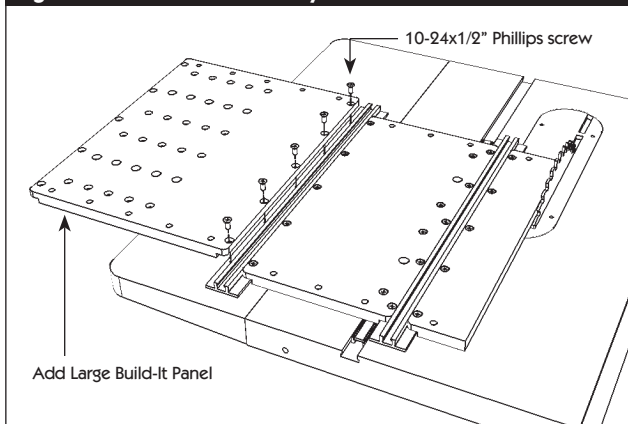

6. Extend Build-It Panel Beyond the Blade

Some jig designs may benefit from workpiece or cutoff support on the opposite side of the blade. A simple "drop panel" locked in place adjacent to the blade provides zero clearance and workpiece cutoff support. Here's how to add one to the Build-It assembly we've been working on.

Lower the blade and remove your Build-It assembly from the left hand miter slot. Drop an INCRA Miter Slider into the right hand miter slot and adjust for a good sliding fit. Using the row of mounting holes that allows the least amount of overhang beyond the line of cut, attach the cutoff reserved from Step 4 to the Miter Slider with the (4) supplied 10-24 x 3/4" flat head Phillips screws. The rabbeted edge on the Build-It Panel should be oriented away from the blade as shown in **Fig. 8**.

Fig. 8 Add "Drop Panel" to Opposite Side of Blade

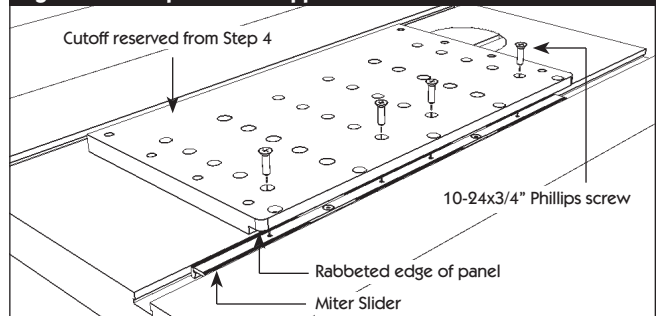

■ 7. Trim Build-It Panel to Blade

Raise the saw blade about 3/4" and make a cut to trim off the portion of the panel that extends beyond the line of cut, **Fig. 9**. Now, when you return the left hand Build-It assembly to the table saw, the right hand "drop panel" can be positioned adjacent to the blade and locked in place by tightening the two Miter Slider expansion mechanisms to provide workpiece cutoff support.

Fig. 10 shows the completed Build-It assemblies put together to create a very useful sliding cutoff sled. The wooden fence shown includes the addition of INCRA's T-Track and T-Track Plus, see **Fig. 11** for dimensions. The fence is held in place with a pair of Build-It Brackets and the knobs included with the brackets. This arrangement allows the fence to be positioned at any location and at any angle on top of the sled. The workpiece is positioned with a user made wooden stop and is securely held in place with the INCRA Build-It Clamp.

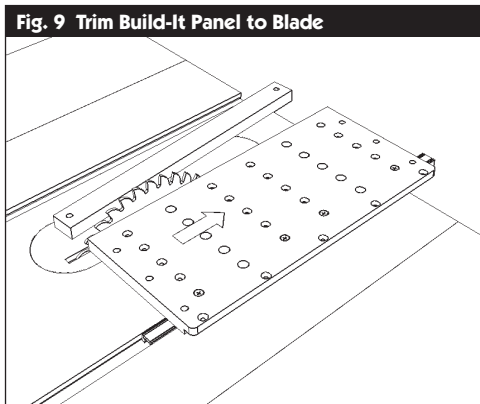

Fig. 9 Trim Build-It Panel to Blade

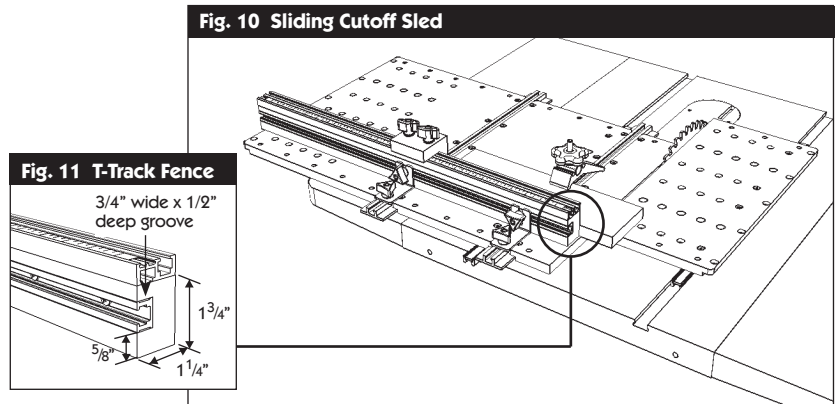
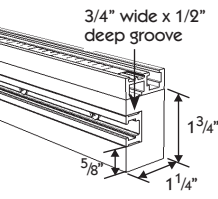

Fig. 10 Sliding Cutoff Sled

Fig. 11 T-Track Fence



Manufactured by:
 Taylor Design Group, Inc.
 P.O. BOX 810262 Dallas, TX 75381
www.incra.com

INCRA is a Registered Trademark of Taylor Design Group
 ©2007 Taylor Design Group, Inc.

INCRA Tools are protected by one or more of the following US patents:
 #4,793,604, #4,930,221, #5,195,730, #5,275,074, #5,423,360, #5,716,045, #6,237,457, #6,557,601, #6,672,190.
 Other patents granted or pending.

